

easee

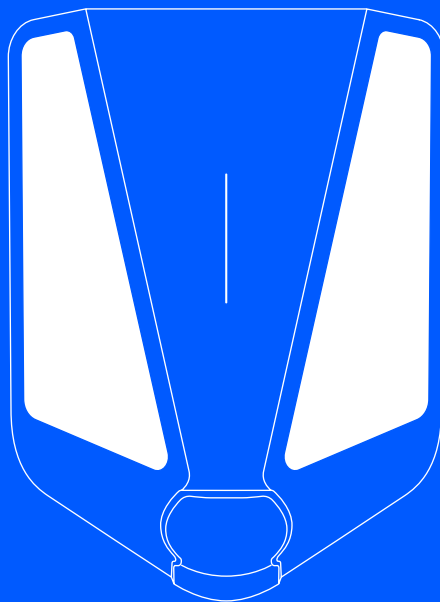

EN Installer guide

Easee Charge Max Eichrecht

Table of contents

Introduction	3
Product overview	4
Technical specifications	5
Planning the installation	8
<hr/>	
Installation Instructions	
Opening	10
Mounting	11
Preparing	11
Wiring	12
Installing	13
Attaching	14
Closing	15
<hr/>	
Features	16
Charging Robot interface	17
MID display interface	19
Eichrecht	20

Introduction

Read the Important product information guide in the product packaging or at support.easee.com before installing the product.

Installation of the product requires a mobile device with NFC or Bluetooth capabilities.

WARNINGS AND CAUTIONS

A Warning indicates a condition, hazard or unsafe practice that can result in serious personal injury or death.

A Caution indicates a condition, hazard or unsafe practice that can result in minor personal injury or damage to the product.

WARNING

This product shall only be installed, repaired or serviced by an authorised electrician. All applicable local, regional and national regulations for electrical installations must be respected.

NOTE

PIN code: The PIN code is required for installation and located on the front of the Chargeberry. It is recommended to keep the PIN code for safe keeping, e.g. inside the fuse cabinet.

Manufacturing Date and Serial Number

The Chargeberry's month and year of manufacture and serial number are on the sticker on the Type-2 socket underneath the charger cover. The production date is displayed in MM/YY format, directly above the serial number, unique to each Chargeberry unit.

The manufacturing date can be found in DD/MM/YY format in the user app. Go to Charger settings, then About, then Manufactured.

Data Protection

Upon Installation and connection to the internet, as an IoT device Easee Charging Robots automatically share data with the Easee cloud (owned by Easee ASA). This makes sure that Easee monitors the charger safety, security, and stability during its lifetime. As a result, some personal data, such as usage patterns, site configurations, and device identifiers, will be processed to provide the smart functionalities of the charger. By using our Chargers, you agree to the collection and processing of some personal data in line with our privacy policy and any applicable data protection laws. If data transfer to the Easee cloud is not desired, we advise users to stop using Easee chargers immediately. For more information, please see Easee Privacy Policy (<https://easee.com/en/privacy/>), available in our website.

Product overview

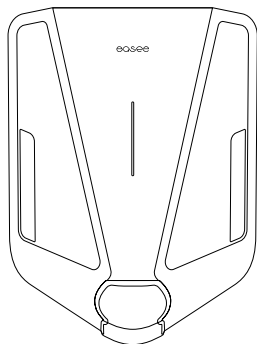

Front cover

Protects the electronics from external influences.

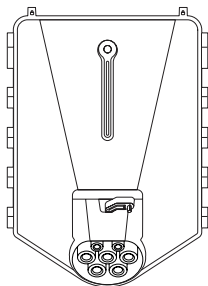

Chargeberry

Contains the electronics for charging the vehicle.

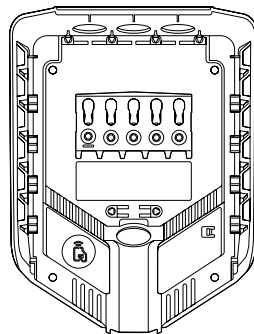

Backplate

For attaching and connecting to the charging infrastructure.

Installation kit



Strain relief
x2



Blind plugs¹
x3



Sealing plug
x2



Strain relief
& front cover
screws (T25)
x 5





Wall screws
(T25)
x 4



Front cover
tool
x 1

Technical specifications

General	
Dimensions	256 x 193 x 106 mm (H x W x D)
Drilling hole distance	c/c 160 x 125 mm (H x W)
Operating temperature	-30 °C to +40 °C Designed for optimal use between -30 °C to +40 °C the charger can operate at temperatures up to +50 °C. Performance may be reduced at higher temperatures.
Weight	1.6 kg
Charging	
Charging power capacity	1.4–22 kW 6 A 1 phase – 32 A 3 phase (automatically adjusted in relation to available capacity) Up to 7.36 kW at 32 A 1 phase Up to 22 kW at 32 A 3 phase
Connection point	Type 2 socket (IEC 62196-2)
Number of phases	1 or 3 (fully dynamic)
Voltage	3x 230/400V AC (±10%)
Mains frequency	50 Hz
Easee Charge MID	Load balancing of up to 3 units per circuit
Built-in energy meter (± 1%)	
Measuring instruments (MID)	
Nominal voltage(s)	230V · 3x230V · 3x230V/400V
Meter type	Static meter
Current measuring range	0.3 - 0.6 (32) A
Reference frequency	50 Hz
Service type	
	
	
Meter constant	1000imp/kWh

Accuracy class index	± 1%
Metering temperature range	-40 °C to + 55 °C
Self consumption	2.5 W idle 5.5 W 1 phase 6.5 W 3 phase
Rated conditional short-circuit current ($I_{cc, 10 ms}$)	960 A
Accuracy class	Active Energy Class B (EN 50470-3:2006)

Connectivity

Built-in eSIM (LTE Cat M1)

WiFi 2.4 GHz b/g/n connection

Easee Link RF™

Control charging via Easee App

RFID/NFC reader

OCPP 1.6 via our API

Bluetooth BLE 4.2

Sensors and indicators

Light stripe with LEDs showing the status of the charger

Touch button

Temperature sensors in all main contacts

Protection

Integrated overload protection according to EN IEC 61851-1:2019

Integrated RCD type A 30 mA AC according to IEC 60947-2, and 6 mA residual direct current detecting device (RCD-DD) complying with IEC 62955, 9.9

Rated conditional short-circuit current ($I_{cc, 60 ms}$)	630 A (does not provide overcurrent protection according to IEC 60947-2)
--	---

Ingress protection rating (IP)	IP54
--------------------------------	------

Impact resistance	IK10
-------------------	------

Insulation class	I ²
------------------	----------------

Pollution degree	4 (installation environment)
------------------	------------------------------

EMC Classification	Class A & Class B
--------------------	-------------------

Overvoltage category	III
----------------------	-----

Circuit breaker	Max 40 A with instantaneous trip, maximum 75 000 A2s.
-----------------	---

² Protection against electric shock in compliance with IEC 60364-4-41, 410.3.3: The Type-2 outlet is protected by "automatic disconnection of supply" (411). The backplate, Chargeberry, and front cover are constructed with "double or reinforced insulation" (412).

Backplate

Installation network	TN, IT or TT (detected automatically)
Installation circuit breaker	Max 40 A Short-circuit current limited to 10 kA
Wire cross-section	2.5 to 16 mm ² (single conductors) / 2.5 to 10 mm ² (parallel conductors) PE cross-section must be equal to or larger than the phase wire cross-section Cable dimensions must adhere either to IEC 60364-5-52 or local regulations
Cable diameter	8-22 mm
Terminal torque	5 Nm (torque tool required)
Cable strip length	12 mm
Ingress protection rating (IP)	IP2X (without cover), IP34 (Easee Ready cover)
Protection against electric shock in compliance with IEC 60364-4-41, 410.3.3: The backplate is constructed with "double or reinforced insulation" (412).	

Planning the installation

Prior to the installation, it is recommended that you consider future charging needs, so that you can easily expand accordingly in the future.

If several Charging Robots are connected to the same circuit, the total current is dynamically distributed between them. The connected Charging Robots communicate wirelessly between each other, ensuring the circuit is not overloaded. The maximum charging current is set during configuration.

For an optimal result

- We always recommend a 3 phase installation if possible, to make it future-proof.
- If possible, use the largest approved cable cross-section (see [Technical specifications](#)).
- Consider the installation of Easee Ready backplates if the acquisition of further Charging Robots is planned for the future.
- To avoid overloading the building's main fuse, the Easee Equalizer can be used for dynamic load balancing. The maximum current value can also be set as required during configuration.

⚠ CAUTION

The MID display is located on the right side of the Chargeberry. Do not mount the charger in a location (for example, in a corner, or next to a pillar) that would block the MID display or prevent proper air cooling.

Special notes

- Several backplates can be connected in parallel.
- If the charging infrastructure includes more than one Charging Robot, the backplate that is configured first becomes the master of its circuit.
- If more than 2 units are installed, the master unit should be located in the middle of the installation (if possible) for an optimal Easee Link communication.
- It is recommended to install the charger in a location where it is shielded from direct sunlight.

- **Site Key:** During installation, a Site Key must be used to assign the Charging Robots to the correct location in the Easee Cloud. A Site Key will automatically be generated when creating a new charging site using the Easee Installer App or it can be obtained by creating a new charging site at [easee.cloud](#).

Your house, power grid and EV

The Charging Robot automatically adapts to the power grid, the electric car and the capacity of the electrical installation. In the table you can see what charging effect you can expect from your installation and situation. The table is only meant as a guide.

⚠ CAUTION

The type of installation as well as cable cross-sections must be determined by a qualified electrician in accordance with valid local, regional and national regulations for electrical systems.

Load	Charging power	
Ampere (A)	1 phase (kW)	3 phase (kW) ³
6	1.4	4.1
8	1.8	5.5
10	2.3	6.9
13	3.0	9
16	3.7	11
20	4.6	13.8
25	5.8	17.3
32	7.4	22

Installation seal

An installation seal can be used to tamper-proof the charger. The recommended seal diameter is 1 - 5mm.

Padlock

It is possible to lock the electronics with a padlock. This will create an extra layer of security (padlock is not included).

Max total lock height	56 mm
Shackle height (outer dimensions)	19 - 20 mm
Shackle thickness	3.2 - 4 mm

Residual Current Device (RCD)

- A Residual Current Device is integrated in the Charging Robot.
- The RCD will break the current in case a residual current exceeding 6mA DC or 30mA AC is detected.
- Disconnection time is according to IEC 60947-2 and IEC 62955.
- The RCD is automatically tested between each charging session or at least every 24h.
- For manual initialization of the RCD-test, please refer to the Installer App.
- The integrated RCD has no influence on the function of external protective devices.

An external RCD is required when at least one of the below conditions are identified:

- The installation, including cable, junction boxes etc., includes components with only basic insulation (Class I).
- Any other electrical equipment apart from Easee Charge Max, including lamps and socket outlets, is connected to the circuit.
- Any other conditions identified by the authorized installer requiring an external RCD.

The internal RCD is considered to provide the required RCD protection for both AC and DC leakage faults when all the below conditions are fulfilled:

- The installation, including cable, junction boxes etc, is performed entirely with components providing double or reinforced insulation (Class II).
- No other electrical equipment apart from Easee Charge Max, including lamps and socket outlets, is connected to the circuit.
- No other conditions identified by the authorized installer requiring an external RCD.

Installation instructions

⚠ WARNING

Always work with the power off and in accordance with local regulations. Use extreme caution and follow instructions carefully.

1 Charging Robot Opening

1. Bend down the lower part of the rubber cover and insert the two ends of the supplied tool into the two openings at the bottom of the front cover.
2. Pull the tool until the front cover comes loose and remove the cover.
3. Grasp the Type 2 socket and push upwards with good force until the Chargeberry disconnects.

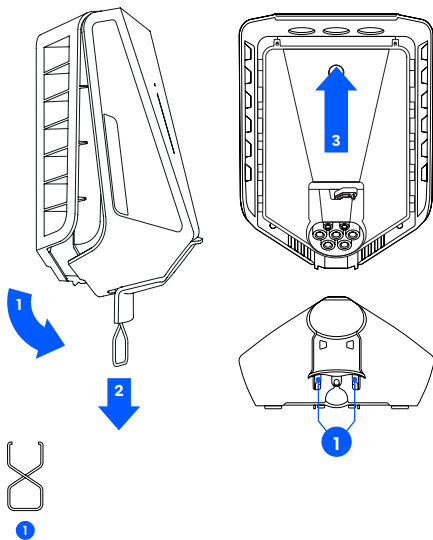

2 Backplate Mounting

1. Fix the backplate to a solid, non-perforated wall or structure with sufficient load-bearing capacity using the 4 wall screws provided in the mounting kit. Use suitable wall plugs for mounting and observe the local regulations for recommended installation height. If you are going to install multiple backplates, now would be a good time to mount them as well.

⚠ CAUTION

- The installation wall must cover the entire back of the product. If this is not possible to achieve, it is possible to use the Easee Mount.
- Original mounting holes must be used to secure the backplate to the wall.
- The area should not be exposed to direct rain, direct sunlight or explosive gases. A physical barrier is recommended to protect the charger.
- Install at a height of 130–140cm, with an angle no more than +/- 3 degrees from vertical. Suggested installation height for accessibility: 80–95 cm.

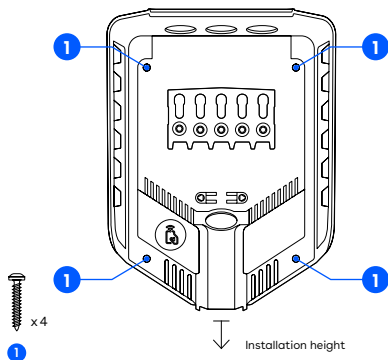

3 Backplate Preparing

1. Shorten the sealing plug to fit the cable. The hole should be slightly smaller to ensure a good seal.
2. Insert the cable through one of the 4 cable entries and secure it to the backplate with the strain relief provided. There must be at least 5 mm of cable extending beyond the strain relief.
3. Close all cable entries that are not in use with the blind sealing plugs supplied.

⚠ CAUTION

The wires must not cross over the screw terminals or the Chargeberry slots. This will prevent the Chargeberry from seating in the slots.

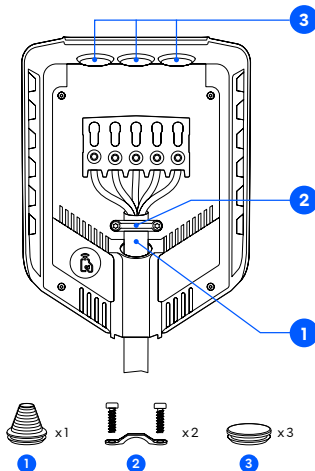

4 Backplate Wiring

- Strip each wire, exposing 12 mm of copper on each. If the cable has flexible conductors, then you must use ferrules on stranded wires to make the connection. Use correct tools to press them.
- Tighten the screw terminal with a torque of 5 Nm.

NOTES

- When connecting multiple backplates in parallel, each screw terminal serves as a coupling point for adjacent backplates.
- It's recommended to follow the existing colour codes used in the installation. Depending on national standards, the colours of the cables can vary from the illustrations. The illustrations in this manual follow the IEC 60445 standard.
- Before turning on the power, make sure the wires are properly connected and tightened to the specified torque. Release cable tension by pulling on each wire and visually inspecting each terminal.
- The PE must have an equal or larger cross-section than the phase wire.

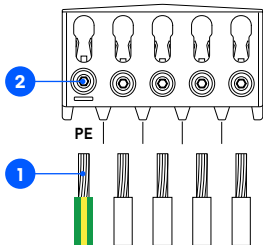

TN/TT 3-phase

(3x 230/400 V)

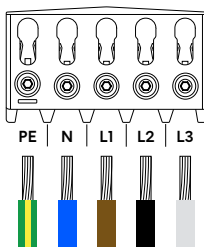

IT/TT 3-phase

(3x 230 V)

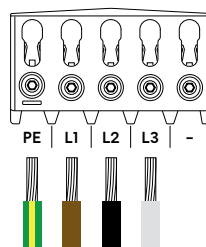

TN 1-phase

(230 V)

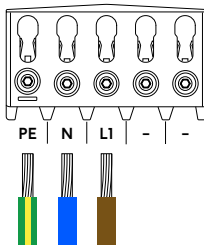

IT/TT 1-phase

(230 V)

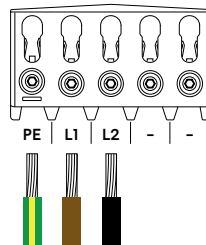

5 Backplate Installing

NOTE

Your phone must support either Bluetooth or NFC.

1. Scan the QR code to download the Easee Installer App and create a free account.
2. Select one of the two site setups in the Installer App:

Create new site: If this is a completely new charging site, select "Create new site". Enter the installation details, follow the on-screen instructions and return to this guide afterwards.

Update existing site: If this site already has one or more Charging Robots installed or if it has been created by an operator, select "Update existing site" and search for the site address. On "Site overview", select the circuit that you want the backplate to be part of and select "Add another backplate". Follow the on-screen instructions and return to this guide afterwards.

NOTE

If the charging circuits include more than one Charging Robot, the backplate that is configured first becomes the master unit of the charging infrastructure. To achieve the best communication flow, the centre backplate should be configured first.



easee.com/installer-app

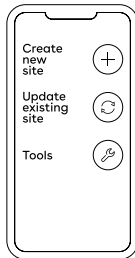

6 Chargeberry Attaching

⚠ WARNING

Insulation testing must be performed **before** a Chargeberry is installed in the backplate. Testing the circuit insulation with the Chargeberry installed in the backplate may damage the electronics or impact the reading negatively.

1. Turn on the power. The terminals of the backplates are now electrically live.
2. Remove the PIN code sticker and attach it to the inside of the fuse cabinet, or another safe location for storage.
3. Position the Chargeberry to fit into the slots on the backplate located in the center of the installation.
4. When the Chargeberry is in the track, press it forcefully down until you hear a "CLICK".

NOTE

You do not need to touch the terminals of either the Chargeberry or the backplate when installing or removing the Chargeberry.

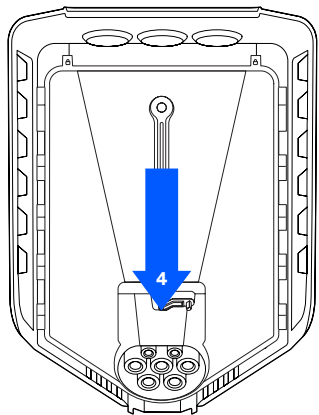
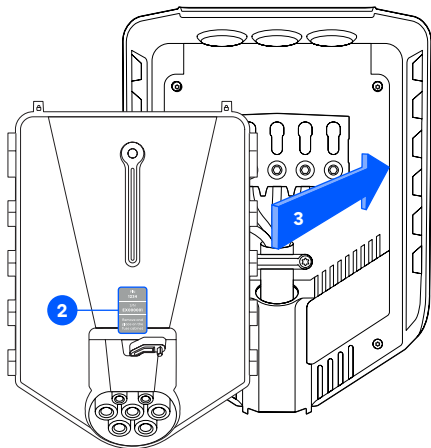

"CLICK!"

7 Front cover Closing

Before closing the front cover, it is possible to lock the Chargeberry with a padlock and/or installation seal (see [Planning the installation](#)).

1. Hang the front cover at the top of the backplate and let it fall into place.
2. Press the bottom of the front cover until you hear a click.

3. Bend the lower part of the rubber cover down.
4. Screw in the locking screw at the bottom of the charger to secure the front cover.

NOTE! The locking screw is necessary to secure the cover and protect the charger from exposure.

5. Close the rubber cover. If the cable is inserted from the bottom, you can cut a corresponding hole in the rubber cover to ensure a neat installation.
6. Remove the protective foil to reveal the MID screen. This step is required for MID compliance.

The charger is now ready for testing according to local regulations. Once complete, transfer ownership to the owner via the Installer App.

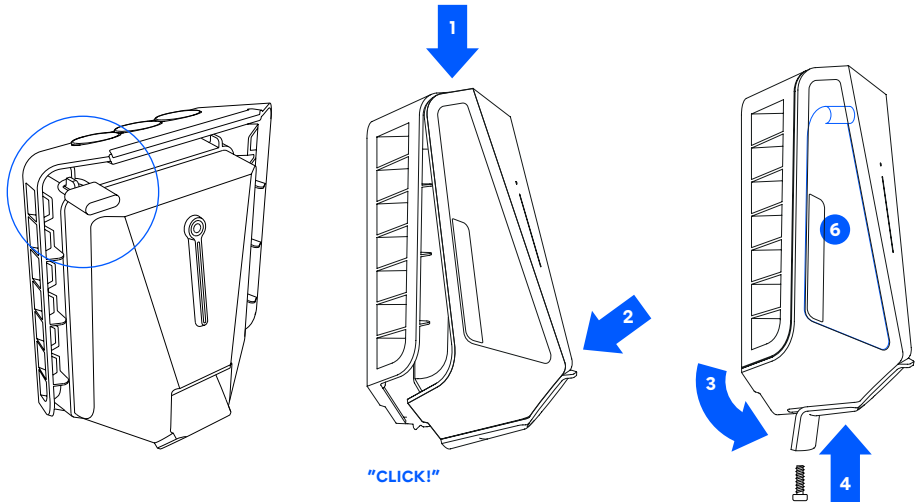

Features

Front view

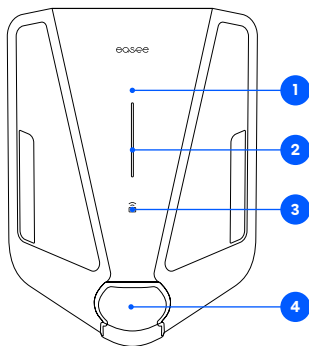

Side view Chargeberry

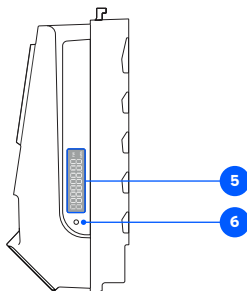



1. **Touch button:** The touch button is used to activate Bluetooth. Bluetooth connection in the app allows for local operation of the charger when no internet is available. Read more about the local interface at: easee.com/support/bt
2. **Light strip:** The light strip communicates the status of the Charging Robot at all times. (See [Charging Robot interface](#)).
3. **RFID area:** The integrated RFID reader enables access control of the Charging Robot and identification of different users. You can use it to unlock the charger with an Easee Key. Check our knowledge base at support.easee.com for more details on how to add and manage your Easee Keys.
4. **Type 2 socket:** The Type 2 socket is completely universal and allows you to charge any type of electric vehicle using the appropriate charging cable. Furthermore, it is possible to permanently lock the charging cable, so you do not have to worry about it being stolen.

NOTE: Adaptors should not be used on the charger or the charging cable. The charging cable must have appropriate sockets on each end.







5. **MID meter display:** The MID meter display shows the cumulative energy in kilowatt hours (kWh).
6. **Infrared (IR) LED:** Pulses with IR light indicating the energy output from the charger.

Charging Robot interface

Light description	Status
White - constant light, only at the bottom 2 LEDs - master unit / 1 LED - secondary units	Standby
White - constant light	Car connected
White - pulsating light	Charging in progress
Blue - constant light	Smart charging enabled (car connected)
Blue - pulsating light	Smart charging in progress
At startup, the LEDs turn on one by one. When the charger is updating, one or more LEDs will flash green while this is in progress.	Updating software (updating can take up to 30 minutes) NOTE! The car must be disconnected before a software update can be completed.
White - flashing light	Waiting for authentication by an RFID tag. Hold the RFID tag against the RFID area of the Charging Robot in order to authenticate and initiate the charging.
White - fast flashing light	RFID-tag received (awaiting key verification)
Red - flashing light, with warning sounds	 WARNING Critical error! Turn off the power and remove the charging cable from the Charging Robot. The power can then be turned back on if necessary. The flashing red light will continue, but the warning sound will stop when the charging cable is disconnected. The charger is blocked from further use, cannot be reset and has to be replaced. Contact customer support.
Red - flashing light	 WARNING Critical error! The charger is blocked from further use, cannot be reset and has to be replaced. Contact customer support.
Red - constant light	General error. Unplug the charging cable and replug it to the Charging Robot. If the red light persists, check the Easee App or our knowledge base ⁴ for further information.

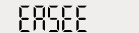
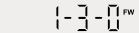
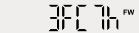
Light description	Status
Red - constant light, with warning sounds	Wires are connected incorrectly.
Red - pulsating light	The Charging Robot has measured an abnormal temperature and has entered in safe mode. Please go to our knowledge base ⁴ for further information.
White - flashing light, only at the bottom	The Charging Robot is searching for its master unit. Please check the status of the master unit. For further information, please check our knowledge base ⁴ .
Yellow - flashing light, only at the bottom	The Charging Robot is waiting to be configured.

MID display interface

Status	Description	Screen
Boot sequence	1. All segments on, for 1 s	
	2. Vertical segments and kWh segment, for 1 s	
	3. Horizontal segments, decimal point and FW segment, for 1 s	
	4. Scrolling "EASEE", for 4 s	
	5. Firmware semantic version (major-minor-patch), for 20 s	
	6. Firmware unique value (16-bit CRC in hexadecimal), for 20 s	
	7. Show energy	
Normal standby mode <i>Cable not connected, not charging</i>	Show accumulated energy	
Charging session open <i>Cable connected, not charging</i>	The three segments at the end blink on and off.	
Charging session open <i>Drawing current, charging</i>	The three segments at the end light sequentially, from 0 to 3. This mimics the image of a charging battery. The sequence is reversed for energy export.	

Eichrecht

Easee Charge Max Eichrecht fulfills the requirements of Eichrecht (MessEV/MessEG), the German framework for calibrated and tamper-proof energy measurement.

The charger contains a certified energy meter that precisely records the delivered energy (kWh) and makes this information available to the user.

Validity of the certificate: 23. Januar 2036.

All measurement data is digitally signed and encrypted before being sent to external systems. This prevents tampering and ensures that consumption data remains accurate for fair and compliant billing.

In accordance with Eichrecht requirements, at least one method for independent verification of session data must be available to the user. This can be provided through a transparency software solution (e.g. S.A.F.E.) that enables access to the original signed measurement data.

Important notice

In rare cases, measurement data for a charging session may not be verifiable by third-party transparency software if a power interruption occurs during charging and the vehicle is disconnected before the power supply is restored. In such cases, the measured session energy remains valid, but the transparency verification process may be affected.

Further legal requirements and information regarding compliance with German Calibration Law can be found in our [knowledge base](#).

Verify measurement data in Easee Portal

1. Log in to portal.easee.com.
2. Locate the charging site.
3. Under "consumption", click the preferred charger.
4. Select the charging session you want to verify.
5. Retrieve the public key* and signed session data in Open Charge Metering Format (OCMF) in the session summary panel.
6. The public key and signed session data can be validated by transparency software (e.g. S.A.F.E.).

Verify measurement data in the Easee app

1. Open the app
2. Tap "charger consumption"
3. Select the charging session you want to verify
4. Retrieve the public key* and signed session data in Open Charge Metering Format (OCMF) in the session summary panel.
5. The public key and signed session data can be validated by transparency software (e.g. S.A.F.E.).

* The public key is also provided on the charger as a QR code for independent verification (see illustration).

For more information about Eichrecht and our interfaces, go to support.easee.com.

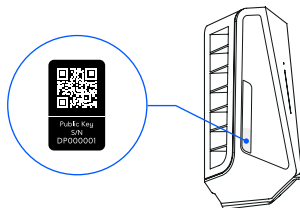

Maintenance

General maintenance

- Ensure that the charger does not have any signs of mechanical damage.
- Visually inspect the Type 2 socket for wear and tear at regular intervals according to local regulations. If the pins are discoloured or damaged, please contact your authorised electrician.

Cleaning

The product does not require cleaning to operate properly. Nevertheless, if the product needs to be cleaned for cosmetic reasons, this is possible.

- Use a damp cloth and an all-purpose household cleaner. Avoid using strong chemicals that contain oil or alcohol, as this will discolour the plastic.
NOTICE! Do not clean the screen with cleaner. Use a dry or damp microfibre cloth only.
- Do not use running water or high pressure water jets.

Repair

If your charger needs to be repaired, please contact your Easee supplier.

Returns and complaints

Contact your distributor or Easee Customer Support regarding the return and complaint of your product.

Customer support

Download the latest manuals, find answers to frequently asked questions and useful documents and videos for your product at support.easee.com.

Practical details

Warranty

The device is free from material defects and is in accordance with laws and regulations for consumer protection in the country where the product is purchased. All correctly installed Easee hardware is covered by our 5 years* limited warranty. If your charger needs to be repaired within this warranty period, please contact your Easee supplier. Further information can be found at support.easee.com.

*Some countries may have extended warranty.

Contact details

Easee IP AS
Vassbotnen 23
4033 Stavanger, Norway
Org. nr: 920 292 046

You can find additional contact details for your country at [easee.com](https://support.easee.com).

The information in this document is for information purposes only, is provided as is, and may be subject to change without notice. Easee IP AS, including its subsidiaries, does not accept any liability for the correctness or completeness of the information and illustrations, and is not liable or responsible for your considerations, assessments, decisions or absence of such, or other use of the information in this document.

No part of this publication may be re-published, reproduced, transmitted or re-used in any other form, by any means or in any form, for your own or any third-party's use, unless otherwise agreed with Easee or its subsidiaries in writing. Any permitted use shall always be done in accordance with good practice and ensure that no harm may be caused to Easee or by misleading the consumer.

Easee and Easee products, product names, trademarks and slogans, whether registered or not, are Easee's intellectual property and may not be used without Easee's prior written permission. All other products and services mentioned may be trademarks or service marks of their respective owners.

March 2026 – Version 1.00

© 2026 by Easee IP AS. All rights reserved.



Easee IP AS
Vassbotnen 23
4033 Stavanger, Norway
www.easee.com